

Airport**Lighting**Company  
An ISO 9001:2015 Certified Company

# INSTRUCTION MANUAL



**LED Elevated Medium Intensity Edge Light  
L861(L), L861E(L), and L861T(L)  
Series ALC-861L**



# LED Elevated Medium Intensity Edge Light L861(L), L861E(L), and L861T(L) Series ALC-861L Instruction Manual

**In accordance with:**  
FAA  
Advisory Circular AC-150/5345-46  
And  
Engineering Brief 67



**Manufactured by:**  
**Airport Lighting Company**  
108 Fairgrounds Drive  
Manlius, New York 13104  
(315) 682-6460

Email: [info@airportlightingcompany.com](mailto:info@airportlightingcompany.com)  
Website: [www.airportlightingcompany.com](http://www.airportlightingcompany.com)

## L-861 (L) LED Edge Light



### Compliances (Current Editions)

FAA: AC 150/5345-46 and Engineering Brief No. 67, ETL Certified

Canada: TP 312, para. 5.3.12.7 and Appendix 5B Table 5B-1



### Application

Runway Edge, Threshold/End, Non Precision Instrument Flight Rules, Displaced Threshold, Taxiway Edge, Apron Edge

### Key Features

- The average LED life is 100,000 hours high intensity / 180,000 hours under typical operating conditions
- Applicable for L-861T (L), L-861 (L) and L-861E (L) requirements
- Colored glass lens for easy day time recognition
- Double sealing system creates watertight head assembly
- Rugged solid state components
- Complies with intensity requirements on 3 or 5 step regulators
- Durable powder coat finish lasts longer
- Reduces power consumption
- Long life LEDs
- Cord set sealed to prevent insect entry
- Threaded 1.5" frangible coupling or optional 2" thread matches existing baseplates/stakes
- IP68

### General Catalog Numbers

ALC-861L-□□-□□-□

#### Lens Colors

BB = Blue  
CC = Clear  
CY = Clear/Yellow  
GG = Green  
GC = Green/Clear  
GO = Green/Opaque  
GY = Green/Yellow  
RR = Red  
RC = Red/Clear  
RG = Red/Green  
RY = Red/Yellow  
YY = Yellow

#### Height

14 = 14"  
20 = 20"  
24 = 24"  
30 = 30"  
Other heights available

#### Options

2 = Frangible coupling with 2" thread for 1" dia. column  
5 = Optional arctic kit (6.6A only)  
V = 90-260 VAC Style 6 plug\*  
VS = 90-260 VAC Style A plug\* includes Flange for desktop

\*Not ETL certified

Example: ALC-861L-RG-24-5 is 24" high with a red/green lens and an optional arctic kit



## Specifications

### Head Assemblies

Includes housing, LED module, cord, power supply, gasket, and lens

#861L-ZZ-XX-L	Head Assembly
#861L-ZZ-XX-V-L	Head Assembly LED (Voltage)*

ZZ = Fixture color

XX = Overall height of fixture -14", 20", 24" or 30" - other heights available

\* - Style 6 plug

### Connector Cords

#766L-X	Cord
---------	------

X = Overall height of fixture -14", 20", 24" or 30" - other heights available

### Lenses

#61L-XX	Lens
---------	------

XX = Lens color \*Including ring

### Columns

#61C-14	7" (14" overall height of fixture)
#61C-20	13" (20" overall height of fixture)
#61C-24	17" (24" overall height of fixture)
#61C-30	23" (30" overall height of fixture)

Other heights available

### Other

#61-GSK	Lens Gasket
#58	Frangible Coupling 1.5" thread for 1" dia. column
#58-2	Frangible Coupling 2" thread for 1" dia. column

### Accessories

#34-010666	L-830-16 10/15W Transformer
#34-020666	L-830-17 20/25W Transformer
#34-030666	L-830-1 30/45W Transformer
#82-D4	L-823 Primary Connector Kit - #8 AWG
#82-S-D4	L-823 Super Connector Kit
#71	L-867B 12" baseplate 1.5" hub
#72	L-867B 12" baseplate 2" hub
#80	Heat shrink tubing - adhesive throughout
#81	Heat shrink tubing - adhesive ends only

### Performance Criteria

All PF ≥ .95

#### Without Arctic Kit

Color	Fixture VA	Total VA	Iso Xfmr
Blue	6.1	10.4	10/15W
Clear	17.9	25.8	20/25W
Yellow	17.9	25.8	20/25W
Clear/Yellow	17.9	25.8	20/25W
Clear/Red	17.9	25.8	20/25W
Red	17.9	25.8	20/25W
Red/Yellow	17.9	25.8	20/25W
Green	14.7	22.1	20/25W
Green/Yellow	14.7	22.1	20/25W
Green/Clear	14.7	22.1	20/25W
Red/Green	9.7	15.5	10/15W
Red/Opaque	9.7	15.5	10/15W
Green/Opaque	9.7	15.5	10/15W

#### With Arctic Kit

Color	Fixture VA	Total VA	Iso Xfmr
Blue	20.1	24.4	20/25W
Clear	31.9	39.8	30/45W
Yellow	31.9	39.8	30/45W
Clear/Yellow	31.9	39.8	30/45W
Clear/Red	31.9	39.8	30/45W
Red	31.9	39.8	30/45W
Red/Yellow	31.9	39.8	30/45W
Green	28.7	36.1	30/45W
Green/Yellow	28.7	36.1	30/45W
Green/Clear	28.7	36.1	30/45W
Red/Green	23.7	29.5	20/25W
Red/Opaque	23.7	29.5	20/25W
Green/Opaque	23.7	29.5	20/25W



<b>How to Get Help</b> .....	<b>1</b>
<b>Warranty</b> .....	<b>2</b>
<b>Introduction</b> .....	<b>3</b>
Ordering .....	<b>3</b>
Part Number Information .....	<b>3</b>
<b>Installation</b> .....	<b>4</b>
Wiring Without an Arctic Kit .....	<b>4</b>
Wiring With an Arctic Kit .....	<b>4</b>
<b>Wiring Diagram</b> .....	<b>5</b>
<b>Troubleshooting</b> .....	<b>6</b>
Single LED and Blue taxiway LED .....	<b>6</b>
Multiple LED .....	<b>7</b>
Replacement Light Engine, Lens, and Drive Board Part Numbers .....	<b>8</b>
Instructions for Replacing a Driver Board .....	<b>9</b>
Instructions for Replacing or Installing an Arctic Kit .....	<b>10</b>
Instructions for Replacing a Lens with Ring .....	<b>11</b>
Instructions for Replacing a Light Engine .....	<b>11</b>
<b>Parts List</b> .....	<b>12</b>
<b>Notes</b> .....	<b>15</b>



## Have Questions? Contact Us:



**PHONE:** (315) 682-6460



**EMAIL:** [info@airportlightingcompany.com](mailto:info@airportlightingcompany.com)



**WEBSITE:** [www.airportlightingcompany.com](http://www.airportlightingcompany.com)

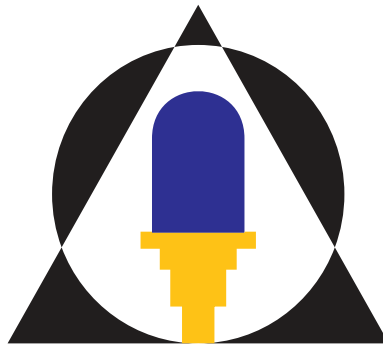

Airport**Lighting**Company

An ISO 9001:2015 Certified Company

**108 Fairgrounds Drive  
Manlius, New York 13104**



## Warranty – LED Light Source Products FAA EB67D

Products manufactured by Airport Lighting Company (ALC) which use LEDs as a light source are warranted against mechanical and physical defects in design or manufacture for a period of 2 years from date of installation per the applicable FAA Advisory Circular and against electrical defects in design or manufacture of the LED or LED specific circuitry for a period of 4 years per FAA EB67D. ALC will correct such defects by repair or replacement, at its option, provided the products have been properly handled and stored prior to installation, properly installed and operated after installation, and provided further that the Buyer has notified ALC in writing within the warranty period and within a reasonable time after notice of such defects. Refer to handling, storage, installation and operational instructions for proper procedural guidance that must be followed to maintain warranty provisions.

This warranty is in effect for the specified term as long as the equipment, in ALC's judgment, has not been altered in such a way as to affect the equipment adversely, subject to accident, negligence, improper storage, and has been operated and maintained in accordance with accepted FAA guidelines as described in AC 150/5340-26 and ALC's published operational guidelines.

ALC reserves the right to examine products about which a claim has been made. Equipment must be presented in the same condition as when the defect was discovered. ALC also reserves the right to require the return of equipment to establish any claim.

**Disclaimer:** ALC's obligation under this warranty is limited to repair or replacement of defective equipment sold by ALC at no cost to Buyer. This does not include any other costs such as the cost of removal, shipping, or installation of the defective part or repaired or replaced product, including labor or any consequential damages of any kind. Warranty services provided under this agreement do not assure uninterrupted operations of LED illuminated equipment. ALC shall not be liable for any indirect or consequential damages.

ALC's liability under no circumstances will exceed its sales price of the products claimed to be defective. All transportation costs under this warranty are the responsibility of the purchaser. Replacement parts and/or equipment provided under this warranty are covered under the same terms until the expiration of the original warranty period that began upon the first installation of the equipment.

This is ALC's sole and exclusive warranty with respect to the equipment sold to the Buyer. There are no express or implied warranties of fitness for any particular purpose or any implied warranties other than those made expressly herein.

ALC shall not be liable to the purchaser of this product or third parties for indirect or consequential damages, or for damages arising from the use of any options or parts other than those designated by ALC as approved products. Damage caused by lightning, flood and other natural or manmade causes are outside the scope of this warranty.

The ALC-861L Series from Airport Lighting Company is a series of elevated LED airfield lights that meet the L861 Medium Intensity Elevated Runway Light, L861E Elevated Runway Threshold Light and the L861T Elevated Taxiway Light specifications. Every light in this series can be delivered with or without an arctic kit.

## ORDERING

Product List	Description
ALC-861L-CC-XX-XX	L861 Medium Intensity, Clear
ALC-861L-YY-XX-XX	L861 Medium Intensity, Yellow / Yellow
ALC-861L-CY-XX-XX	L861 Medium Intensity, Clear / Yellow
ALC-861L-RC-XX-XX	L861 Medium Intensity, Red / Clear
ALC-861L-RY-XX-XX	861 Medium Intensity, Red / Yellow
ALC-861L-GY-XX-XX	L861 Medium Intensity, Green / Yellow
ALC-861L-GC-XX-XX	L861 Medium Intensity, Green / Clear
ALC-861L-GG-XX-XX	L861 Medium Intensity, Green
ALC-861L-RG-XX-XX	L861E Edge Light, Red / Green
ALC-861L-RR-XX-XX	L861E Edge Light, Red
ALC-861L-GO-XX-XX	L861E Edge Light, Green/ Obscure
ALC-861L-BB-XX-XX	L861T Taxiway Light, Blue

## PART NUMBER INFORMATION

ALC-861L-□□-□□-□

### Lens Colors

BB = Blue  
 CC = Clear  
 CY = Clear/Yellow  
 GG = Green  
 GC = Green/Clear  
 GO = Green/Opaque  
 GY = Green/Yellow  
 RR = Red  
 RC = Red/Clear  
 RG = Red/Green  
 RY = Red/Yellow  
 YY = Yellow

### Height

14 = 14"  
 20 = 20"  
 24 = 24"  
 30 = 30"  
 Other heights available

### Options

2 = Frangible coupling with 2" thread for 1" dia. column  
 5 = Optional arctic kit (6.6A only)  
 V = 90-260 VAC Style 6 plug\*  
 VS = 90-260 VAC Style A plug\* includes Flange for desktop

\*Not ETL certified

Example: ALC-861L-RG-24-5 is 24" high with a red/green lens and an optional arctic kit





The ALC-861L Elevated LED fixtures mount to a 1½" – 12 NF base plate or can be specially ordered to mount on a 2" NPS baseplate. The fixture ships from Airport Lighting Company ready to be plugged into an appropriate L830 Style isolation transformer with a 6.6amp output. Snake the cord through the column and frangible coupling, then plug the fixture into the isolation transformer secondary. Thread the frangible coupling onto the baseplate. Secure the column to the frangible coupling. The ALC-861L bi-directional fixtures are assembled so that the 2 clasps that hold through the glass lens are on the dividing line of the bi-directional colors. Line the ALC-861L up so that a line thru the clasps is perpendicular to the runway and the colors are in the correct orientation. Place a torpedo level along the bottom edge of the light fixture base. Using the (3) ¼"-20 hex screws in the base of the fixture adjust the screws until the light fixture is level and tighten to 30 in-lbs.

Wipe the lens clean. Power the constant current regulator and check that the LEDs come on. Run through all the steps of the regulator and make sure that the light intensity increases as the current is increased. The fixture is ready to provide years of quality service.

## Wiring Without an Arctic Kit

The ALC-861L fixture leaves the factory ready to be connected to a 6.6A output isolation transformer. The secondary of the isolation transformer plugs into the fixture power cord. The power cord connects to 2 tabs on the driver board with quick connect terminals. The driver board connects to the LED light engine with a 2-position inline connector.

## Wiring With an Arctic Kit

The ALC-861L fixture leaves the factory ready to be connected to a 6.6A output isolation transformer. The secondary of the isolation transformer plugs into the fixture power cord. The power cord connects to the driver board and arctic kit in series. The remaining arctic kit power lead plugs into the remaining tab on the driver board. The driver board connects to the LED light engine with a 2-position inline connector. The driver board connects to the arctic kit control circuit with a 3-position inline connector.



## Wiring Without an Arctic Kit

ALC-861L LED Fixture

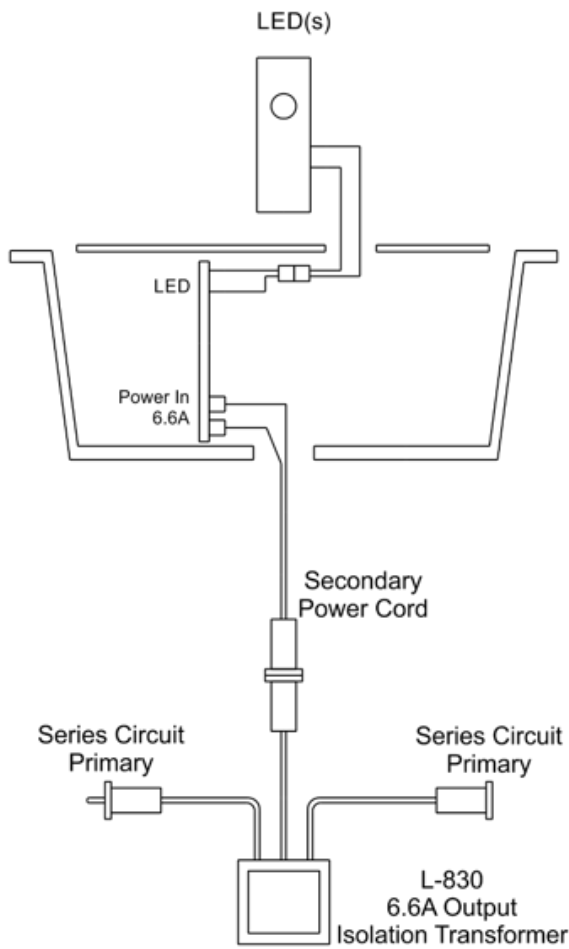

## Wiring With an Arctic Kit

ALC-861L LED Fixture w/ Arctic Kit

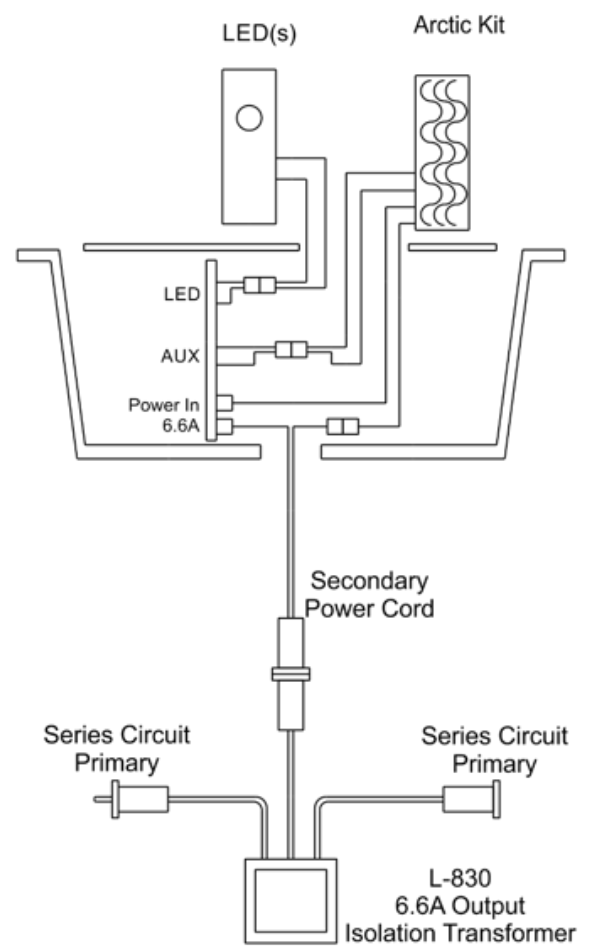

The light fixture has two replaceable electrical parts, a driver board and a light engine. If the light engine fails the below test, replace the light engine. If the replacement of the light engine does not cause the fixture to work, additionally replace the driver board.

## Diode test of ALC-861L Fixtures

An LED is a Light Emitting Diode. A diode test can be performed on an LED. The Airport Lighting Company ALC-861L family of products use different LEDs in various configurations. In some configurations, there will be a single LED and in others there will be multiple LEDs.



**Single white LED and blue taxiway LED.**

1. Turn off the power and lockout the Constant Current Regulator
2. Make sure the test probes are in the proper configuration on the multi-meter—Red to positive, and Black to negative voltage inputs.
3. Turn multi-meter to diode test
4. Unplug the LED Light engine from the driver board
5. Place the Red probe on the + (positive/anode) solder point on the LED circuit board
6. Place the black probe on the – (negative/cathode) solder point
7. If the LED lights up, the LED is OK. Some LEDs can be quite dim in these test circumstances. You may not see the LED light up if the test area is brightly lit or outdoors during the day.
8. If the meter reads 1.7 – 3.0 VDC, LED is OK
9. If the LED is not OK, replace the light engine

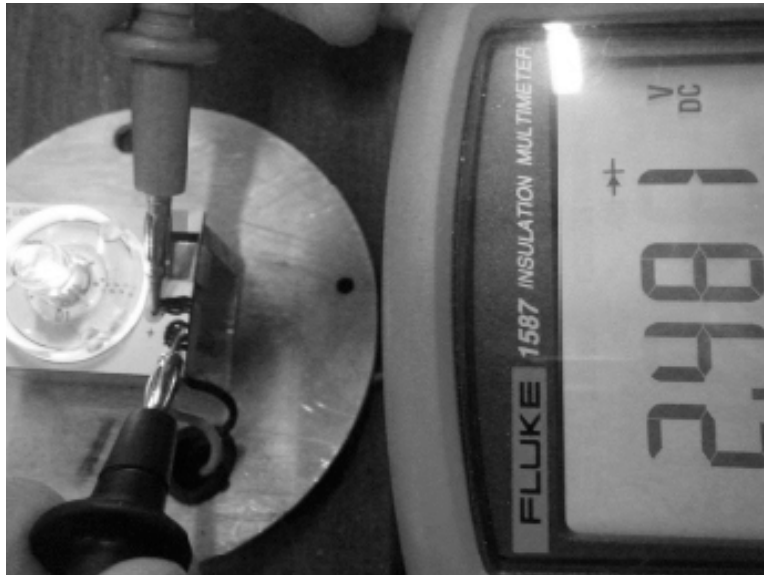

## **Narrow Boards used on fixtures that use more than one LED.**

On the fixtures with multiple of LEDs a common printed circuit board is used. On the circuit board are two test points for the diode test. The diode test needs to be done on each LED at the location of the test points. The procedure for testing each LED is as follows:

1. Turn off the power and lockout the Constant Current Regulator
2. Make sure the test probes are in the proper configuration on the multi-meter—Red to positive, and Black to negative voltage inputs.
3. Turn multi-meter to diode test
4. Unplug the LED Light engine from the driver board
5. Place the Red probe on the + (positive/anode) test point on the LED circuit board
6. Place the black probe on the – (negative/cathode) test point
7. If the LED lights up, the LED is OK. Some LEDs can be quite dim in these test circumstances. You may not see the LED light up if the test area is brightly lit or outdoors during the day.
8. If the meter reads 1.7 – 3.0 VDC, LED is OK
9. Repeat steps 5 thru 8 for each LED in the fixture
10. If the LED is not OK, replace the light engine



## Replacement Light Engine, Lens, and Driver Board Part Numbers

L Type	Color	Light Engine	Lens with Ring	Driver Board
L-861	Clear	861LEDMOD-CC	61L-CC	61PCB-PWR-HC
L-861	Clear / Yellow	861LEDMOD-CC	61L-CY	61PCB-PWR-HC
L-861	Clear / Red	861LEDMOD-CC	61L-CR	61PCB-PWR-HC
L-861	Yellow	861LEDMOD-CC	61L-YY	61PCB-PWR-HC
L-861	Yellow / Red	861LEDMOD-CC	61L-YR	61PCB-PWR-HC
L-861	Green	861LEDMOD-GG	61L-GG	61PCB-PWR-LC-GG
L-861	Green / Clear	861LEDMOD-GC	61L-GC	61PCB-PWR-LC-GC
L-861	Green / Yellow	861LEDMOD-GY	61L-GY	61PCB-PWR-LC-GY
L-861E	Red	861LEDMOD-CC	61L-RR	61PCB-PWR-HC
L-861E	Red / Green	861LEDMOD-RG	61L-RG	61PCB-PWR-LC-RG
L-861E	Green / Obscure	861LEDMOD-GO	61L-GO	61PCB-PWR-LC-GO
L-861T	Blue	861LEDMOD-BB	61L-BB	61PCB-PWR-LC

## Instructions for Replacing a Driver Board

1. Turn off the power and lockout the Constant Current Regulator
2. Remove the lens with ring by opening the 2 clasps
3. Remove the 2 screws holding down the light engine
4. Unplug the LED connector and remove the light engine
5. Note grooves where the driver board slides into the base casting
6. Remove the red hold down board
7. Unplug the driver board and remove
8. Check that there is a thermal pad with a protective sheet on the driver board aluminum heatsink
9. Peel the protective sheet off of the thermal pad
10. Slide the new driver board into the base grooves
11. Make sure the thermal pad contacts the base
12. Plug the wire power terminals onto the driver board tabs
13. Reinstall the red hold down board
14. Inspect the base and make sure it is clean along the inside edge
15. Plug the LED connector
16. Place the light engine in place so that the thru hole is on the side opposite the driver board
17. Screw in the 2 screws holding down the light engine
18. Note the 2 tabs on the outside of the base
19. Note the 2 recesses on the inside of the lens ring
20. Note the 2 tabs on the outside of the base
21. Note the 2 recesses on the inside of the lens ring
22. Check the orientation of the glass lens. Making certain that the color of glass is on the same side as the color of the LEDs (when applicable)
23. The glass lens ring has 2 recesses which will fall over the 2 tabs on the outside of the light base
24. When the lens with ring is in place, clip the 2 clasps down
25. Power up the fixture and check that the LEDs are lighting up correctly

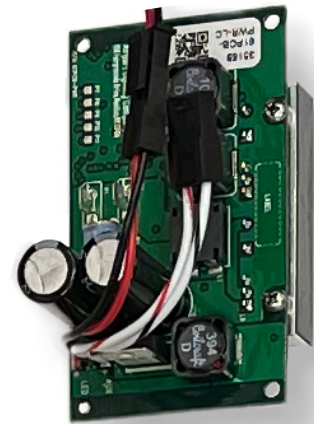

## Instructions for Replacing or Installing an Arctic Kit

1. Turn off the power and lockout the Constant Current Regulator
2. Remove the lens with ring by opening the 2 clasps
3. Remove the 2 screws holding down the light engine
4. Unplug the LED inline connector and remove the light engine
5. Unplug the Arctic Kit inline connector, for arctic kit control circuit
6. Unplug the Arctic Kit Power connectors, at driver board, and on primary incoming power connection
7. Remove the Arctic Kit from the light engine disk by squeezing the snap in standoffs on the underside of the light engine disk
8. On most fixture the arctic Kit will slide off over the LED light engine, on fixture that use 6 LEDs, the LED mount needs to be removed from the light engine.
9. Take a new Arctic Kit and orient it so the 3 standoffs are over the 3 holes in the light engine disk.
10. Pass the wires thru the opening in the light engine disk
11. Snap the Arctic Kit in place
12. Connect the power leads, the male lead connects to the incoming power lead, the female lead connects to the driver board
13. Connect the Arctic Kit inline connector, for Arctic Kit control
14. Screw in the 2 screws holding down the light engine Note the 2 tabs on the outside of the base
15. Note the 2 recesses on the inside of the lens ring
16. Note the 2 recesses on the inside of the lens ring
17. Check the orientation of the glass lens. Making certain that the color of glass is on the same side as the color of the LEDs (when applicable)
18. The lens ring has 2 recesses which will fall over the 2 tabs on the outside of the light base
19. When the lens with ring is in place, clip the 2 clasps down
20. Power up the fixture and check that the LEDs are lighting up correctly
21. When the temperature outside is below freezing, the lens should feel warm after operating at 6.6 amps for 10-15 minutes
22. A very small red LED will light up when the heater is activated





## Instructions for Replacing a Lens with Ring

1. Turn off the power and lockout the Constant Current Regulator
2. Remove the lens with ring by opening the 2 clasps
3. Clean the inside of the fixture
4. Note the 2 tabs on the outside of the base
5. Note the 2 recesses on the inside of the lens ring
6. Check the orientation of the glass lens. Making certain that the color of glass is on the same side as the color of the LEDs (when applicable)
7. The lens ring has 2 recesses which will fall over the 2 tabs on the outside of the light base
8. When the lens with ring is in place, clip the 2 clasps down
9. Power up the fixture and check that the LEDs are lighting up correctly



## Instructions on Replacing a Light Engine

1. Turn off the power and lockout the Constant Current Regulator
2. Remove the lens with the ring by opening the 2 clasps
3. Remove the two screws holding down the light engine
4. Unplug the LED connector and remove the light engine
5. Inspect the base and make sure it is clean along the inside edge
6. Plug in the new LED connector
7. Place the new light engine in place so that the thru hole is on the side opposite the driver board
8. Screw in the 2 screws holding down the light engine
9. Note the two tabs on the outside of the base
10. Note the two recesses on the inside of the lens ring
11. Check the orientation of the glass lens. Making certain that the color of the glass is on the same side as the color of the LEDs (when applicable)
12. The lens ring has 2 recesses which will fall over the 2 tabs on the outside of the light base
13. When the lens ring is in place, clip the 2 clasps down
14. Power up the fixture and check that the LEDs are lighting up correctly

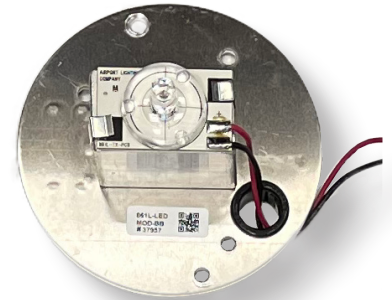





# PARTS LIST



AirportLightingCompany

An ISO 9001:2015 Certified Company

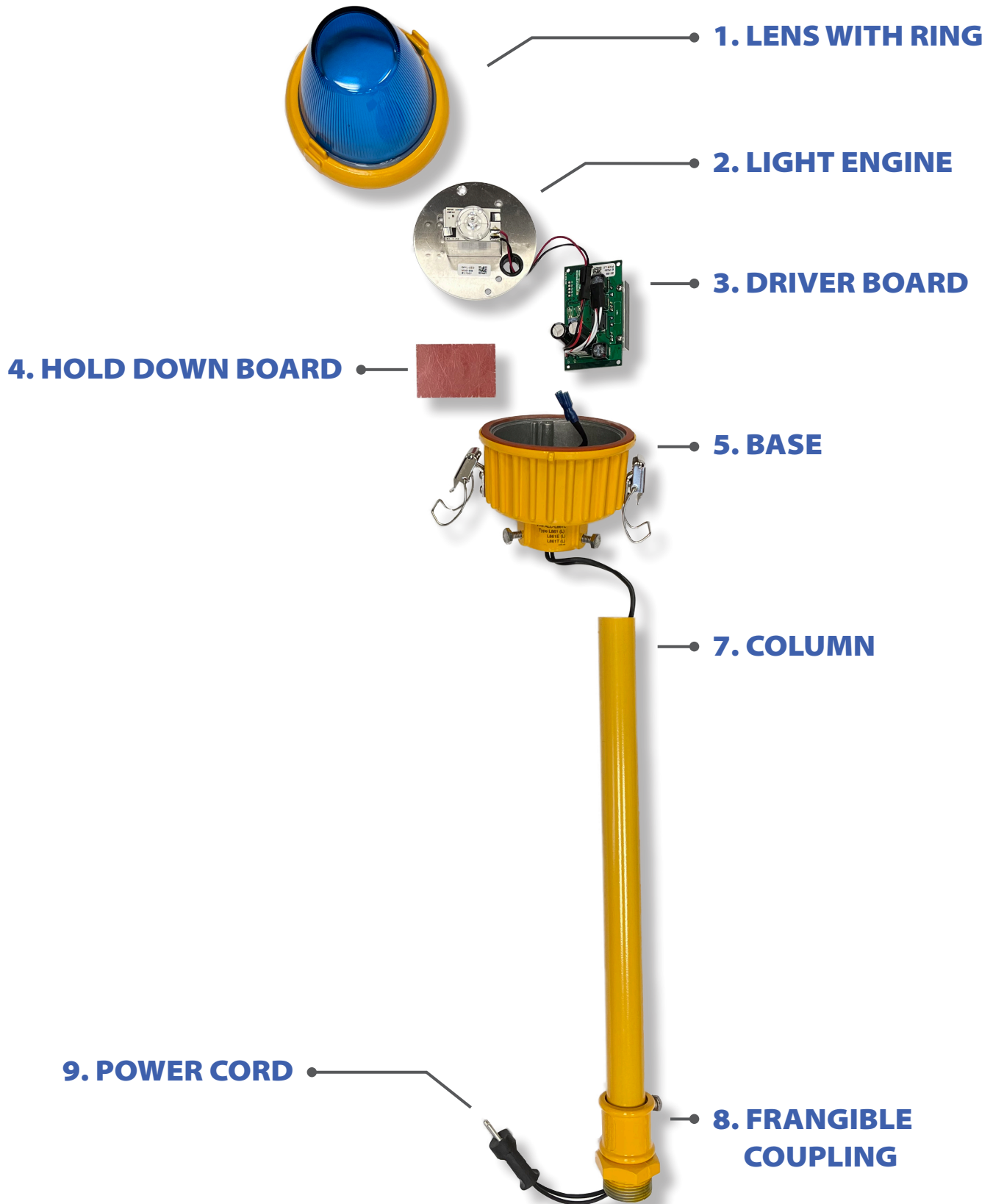



## Parts List Fixture Type ALC-861L

ITEM #	Part Name/Description	Part #	
<b>1</b>	<b>LENS WITH RING</b>		
	Clear/Red	61L-CR	
	Clear	61L-CC	
	Clear/Yellow	61L-CY	
	Yellow/Red	61L-YR	
	Green/Yellow	61L-GY	
	Green/Clear	61L-GC	
	Red/Green	61L-RG	
	Red	61L-RR	
	Green/Obscure	61L-GO	
	Lens Blue	61L-BB	
	Lens Green	61L-GG	
	<b>2</b>	<b>LIGHT ENGINES</b>	
		Clear	861LEDMOD-CC
Clear/Yellow		861LEDMOD-CC	
Clear/Red		861LEDMOD-CC	
Yellow/Red		861LEDMOD-CC	
Yellow		861LEDMOD-CC	
Red		861LEDMOD-CC	
Green/Clear		861LEDMOD-GC	
Green/Yellow		861LEDMOD-GY	
Green		861LEDMOD-GG	
Red/Green		861LEDMOD-RG	
Green/Oscure		861LEDMOD-GO	
Blue		861LEDMOD-BB	



## Parts List Fixture Type ALC-861L

ITEM #	Part Name/Description	Part #
<b>3</b>	<b>DRIVER BOARDS</b>	
	Low Current Driver	61PCB-PWR LC
	High Current Driver	61PCB-PWR HC
<b>4</b>	<b>HOLD DOWN BOARD</b>	61-HDB
<b>5</b>	<b>L861 BASE</b>	217B-BA
<b>6</b>	<b>STRAIN RELIEF</b>	99-00109
<b>7</b>	<b>COLUMNS</b>	
	7" Column	61C-14
	13" Column	61C-20
	17" Column	61C-30
	23" Column	61C-30
<b>8</b>	<b>FRANGIBLE COUPLING</b>	58
<b>9</b>	<b>POWER CORDS</b>	
	L823 Plug w/Cord 14 Inch OAH	61-14
	L823 Plug 20 Inch OAH	61-20
	L823 Plug w/Cord 24 Inch OAH	61-24

