

Airport**Lighting**Company
An ISO 9001:2015 Certified Company

OWNER'S MANUAL



High Intensity LED Runway Light
L-862(L), L-862E(L) LED





Airport**Lighting**Company

An ISO 9001:2015 Certified Company

Elevated High Intensity L-862(L), L862E(L) LED LED Runway Light Owner's Manual

In accordance with:

FAA

Advisory Circular AC-150/5345-46
Engineering Brief 67

ICAO Annex 14

Transport Canada TP312



Manufactured by:

Airport Lighting Company

108 Fairgrounds Drive
Manlius, New York 13104
(315) 682-6460

Email: info@airportlightingcompany.com

Website: www.airportlightingcompany.com



L-862(L), L-862E(L) High Intensity LED Light



Compliances

FAA: L-862(L) and L-862E(L) AC 150/5345-46 and Engineering Brief No. 67 (Current Edition)

Canada: TP 312

ICAO: Annex 14, Volume 1



Applications

Runway Edge, Threshold, Displaced Threshold, Threshold/End, Displaced Threshold Precision IFR Runways

Key Features

- Long Life LEDs for over 56,000 hours of service
- Light clarity ensured for years with glass lens.
- Dimmable to FAA intensity curve from 2.8 amp to 6.6 amps.
- Fixtures without arctic kits use 30/45W isolation transformers, fixtures with arctic kits use 65W isolation transformers.
- Plug and Know circuit design. Dynamic controller senses the attached light engines, allowing for greater service flexibility.
- Daytime recognition provided on lens retainers
- Leveling surface and sighting cross on cap eliminates the need for an aiming device
- Fixture surface area designed to meet LED thermal requirements

General Catalog Numbers

EHL-□□-□□-□

Side A

Side B

Mounting Height

Options

0 = No Arctic Kit
5 = Arctic Kit

W = White
Y = Yellow
R = Red
G = Green (FAA)
I = Green (ICAO / TP312)
O = Obscure

14 = 14"
20 = 20"
24 = 24"
30 = 30"

Example: EHL-RG-24 is 24" high with Red on Side A and Green on Side B.

*IO / OI Only



Specifications

Dimensions & Weight

Height, head assembly	6.8 inches
Height, w/ slip fitter	8.9 inches
Width	5.5 inches
Length	5.2 inches
Weight	7.2 pounds

The L862 fixtures ship in a single box (9 1/8 x 5 3/4 x 7) or in a case of 18 (18 x 17 x 16).

View runway edge lights from runway centerline perpendicular to fixture when determining color in conjunction with right-hand and left-hand fixtures. The first color will be on the left toe-in side of the light fixture.

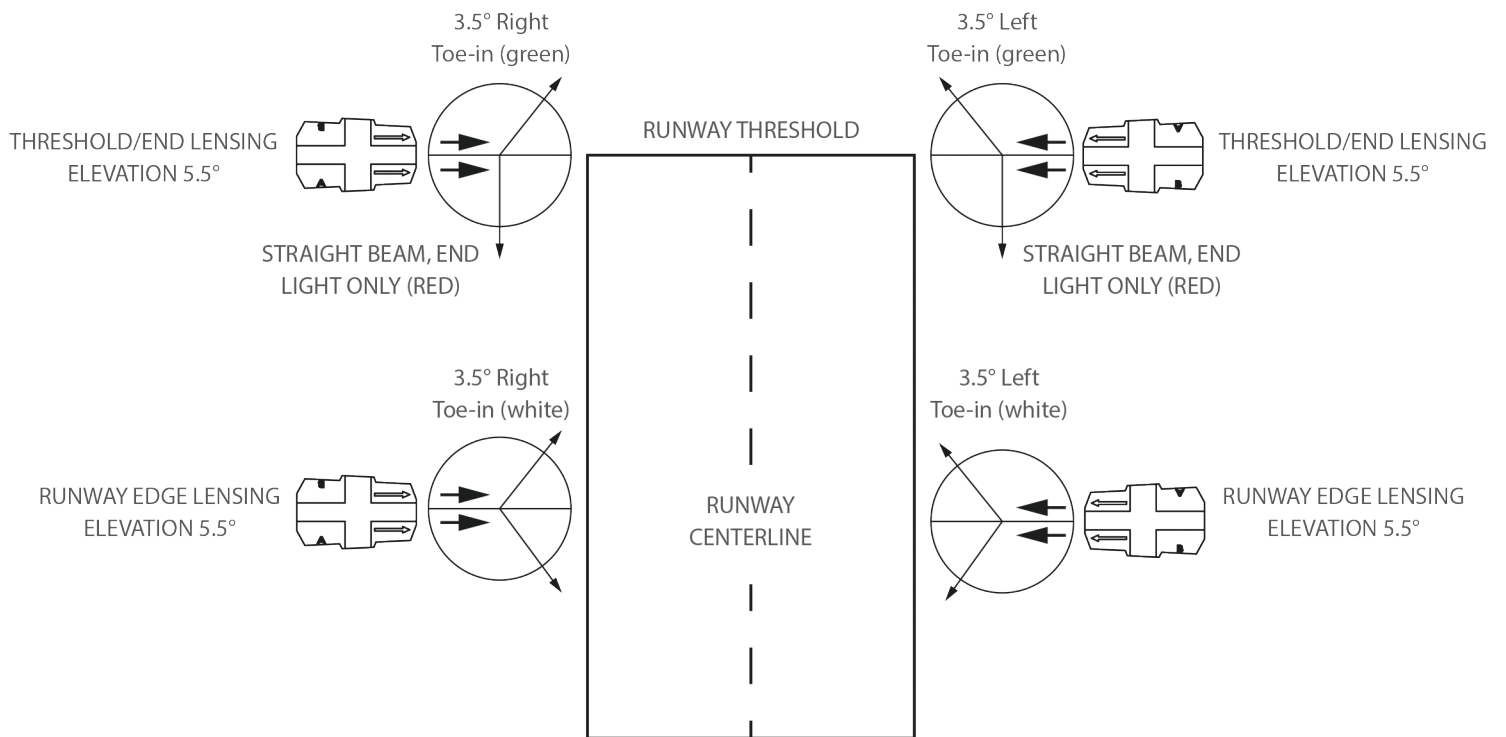



Fixture Loads

Volt / Amp Loads

Without Heater

Bidirectional

Color	VA Load*	Transformer Size
White & White	54.5	65W
White & Yellow	55.7	65W
White & Red	55.1	65W
Green & Yellow	49.6	65W
Red & Yellow	53.7	65W
Red & Green	45	65W
Red & Red	55.2	65W

Unidirectional

Color	VA Load*	Transformer Size
Green	27.4	65W
Red	34.1	65W

Volt / Amp Loads

With Heater

Bidirectional

Color	VA Load*	Transformer Size
White & White	65.4	65W
White & Yellow	66.6	65W
White & Red	66	65W
Green & Yellow	60.5	65W
Red & Yellow	64.6	65W
Red & Green	55.9	65W
Red & Red	66.1	65W

Unidirectional

Color	VA Load*	Transformer Size
Green	32.85	65W
Red	39.55	65W

TABLE OF CONTENTS



Airport**L**ightingCompany

An ISO 9001:2015 Certified Company

How to Get Help	1
Warranty	2
Safety	3
Description	4
Catalog Ordering Information	4
L862 Fixtures	4
L862E Fixtures	5
ICAO / TP312 Fixtures	6
Dimensions	7
Storage	7
Installation	8
FAA References and Siting Requirements	8
Installation	8
Tools Required for Installation	8
Tools Required for Maintenance	8
Installation Precautions	8
Install Proper Transformer	8
Install Fixture	9
Install Frangible Coupling	9
Aim Fixture	9
Level Fixture	10
Torque Bolts	10
Operation	11
Plug and Know LED Circuit	11
Multiple Light Devices	11
Arctic Kit	11
Maintenance	12
Daily Maintenance	12
Monthly Maintenance	12



Troubleshooting	13
Tech Support	13
Replacing Electronic Parts	14-15
Parts	16-20
Wiring Diagrams	21-24
Notes	25

List of Figures

Figure 1: Light Placement	4
Figure 2: Side A, Side B	5
Figure 3: Fixture Dimensions	7
Figure 4: Fixture Aiming	9
Figure 5: Leveling, Front View	10
Figure 6: Leveling, Side View	10
Figure 7: Electronic Component Assembly	14
Figure 8: How to Remove Ferrule	15
Figure 9: Parts Diagram	17
Figure 10: Arctic Kit Parts	18
Figure 11: Schematic, Bi-directional Fixture	21
Figure 12: Schematic, Bi-directional Arctic Kit	22
Figure 13: Schematic, Uni-directional Fixture	23
Figure 14: Schematic, Uni-directional with Arctic Kit	24

List of Tables

Table 1: Torque	10
Table 2: Troubleshooting	13
Table 3: Light Engines	16
Table 4: Columns and Cords	16
Table 5: Bill of Materials	19
Table 6: Arctic Kit Bill of Materials	20



Have Questions? Contact Us:



PHONE: (315) 682-6460



EMAIL: info@airportlightingcompany.com



WEBSITE: www.airportlightingcompany.com

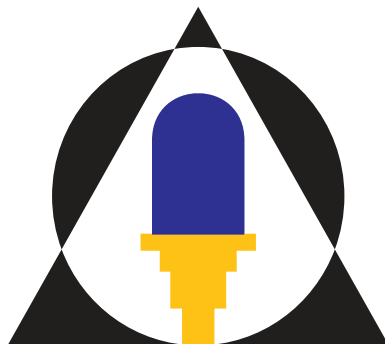

Airport**Lighting**Company

An ISO 9001:2015 Certified Company

**108 Fairgrounds Drive
Manlius, New York 13104**



Statement of Warranty

Products manufactured by Airport Lighting Company (ALC) which use LEDs as a light source are warranted against mechanical and physical defects in design or manufacture for a period of 2 years from date of installation per the applicable FAA Advisory Circular and against electrical defects in design or manufacture of the LED or LED specific circuitry for a period of 4 years per FAA EB67D. ALC will correct such defects by repair or replacement, at its option, provided the products have been properly handled and stored prior to installation, properly installed and operated after installation, and provided further that the Buyer has notified ALC in writing within the warranty period and within a reasonable time after notice of such defects. Refer to handling, storage, installation and operational instructions for proper procedural guidance that must be followed to maintain warranty provisions.

This warranty is in effect for the specified term as long as the equipment, in ALC's judgment, has not been altered in such a way as to affect the equipment adversely, subject to accident, negligence, improper storage, and has been operated and maintained in accordance with accepted FAA guidelines as described in AC 150/5340-26 and ALC's published operational guidelines.

ALC reserves the right to examine products about which a claim has been made. Equipment must be presented in the same condition as when the defect was discovered. ALC also reserves the right to require the return of equipment to establish any claim.

Disclaimer: ALC's obligation under this warranty is limited to repair or replacement of defective equipment sold by ALC at no cost to Buyer. This does not include any other costs such as the cost of removal, shipping, or installation of the defective part or repaired or replaced product, including labor or any consequential damages of any kind. Warranty services provided under this agreement do not assure uninterrupted operations of LED illuminated equipment. ALC shall not be liable for any indirect or consequential damages.

ALC's liability under no circumstances will exceed its sales price of the products claimed to be defective. All transportation costs under this warranty are the responsibility of the purchaser. Replacement parts and/or equipment provided under this warranty are covered under the same terms until the expiration of the original warranty period that began upon the first installation of the equipment.

This is ALC's sole and exclusive warranty with respect to the equipment sold to the Buyer. There are no express or implied warranties of fitness for any particular purpose or any implied warranties other than those made expressly herein.

ALC shall not be liable to the purchaser of this product or third parties for indirect or consequential damages, or for damages arising from the use of any options or parts other than those designated by ALC as approved products. Damage caused by lightning, flood and other natural or manmade causes are outside the scope of this warranty.

Safety

It is not safe to work on a constant current power system when the power is on. Make sure the power is off before installing a runway light fixture. A lock out, tag out, procedure should be used. An additional safety measure is to test that the circuit is off by using a clamp-on ammeter. By using a clamp-on ammeter, clamped over the primary cable of the isolation transformer, the installer can confirm that the circuit being worked on is off by verifying that no current is flowing thru the primary cable.





DESCRIPTION



AirportLightingCompany

An ISO 9001:2015 Certified Company

Description

The High Intensity LED Runway Lights are elevated bi-directional and uni-directional runway lights. The High Intensity LED Runway Light operate on a 2.8 - 6.6 Amp series runway circuit.

FAA: This product line meets the requirements for L862 and L862E

ICAO: This product line meets the standards as shown Appendix 2, A2-3 (green threshold light), A2-8 (red runway end light), and A2-10 (white, yellow and red runway edge light where width of runway is 60m).

TP312: This product line meets the standards as shown in Appendix B.1.3 (green threshold light), B.1.9.3 (red runway end light), and B.1.11 (white, yellow and red runway edge light where width of runway is 60m).

Catalog Ordering Information

L-862(L) Fixtures

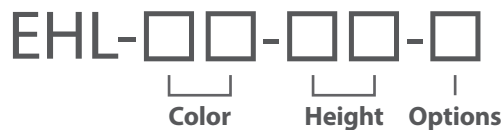

Color	Height	Options
WW = White / White	14 = 14" (36cm)	5 = Arctic Kit
WY = White / Yellow	20 = 20" (51cm)	
YW = Yellow / White	24 = 24" (61cm)	
WR = White / Red	30 = 30" (76cm)	
RW = Red / White	Other heights available	
GY = Green / Yellow		
YG = Yellow / Green		
RY = Red / Yellow		
YR = Yellow / Red		

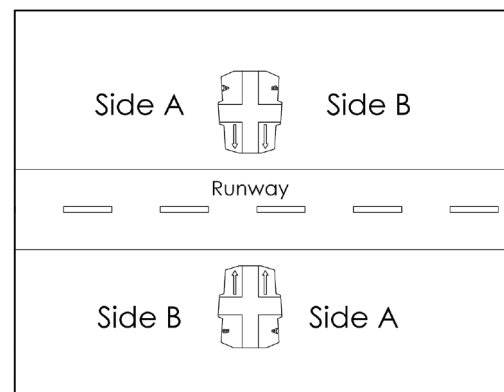

Figure 1: Light Placement

Example: EHL-WY-24 is 24" high fixture with white on side A and yellow on side B.



Catalog Ordering Information Continued

L-862E(L) Fixtures

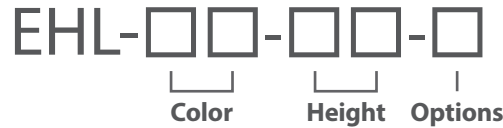

Color	Height	Options
RR = Red / Red	14 = 14" (36cm)	5 = Arctic Kit
RG = Red / Green	20 = 20" (51cm)	
GR = Green / Red	24 = 24" (61cm)	
RO = Red / Obscure	30 = 30" (76cm)	
OR = Obscure / Red	Other heights available	
GO = Green / Obscure		
OG = Obscure / Green		

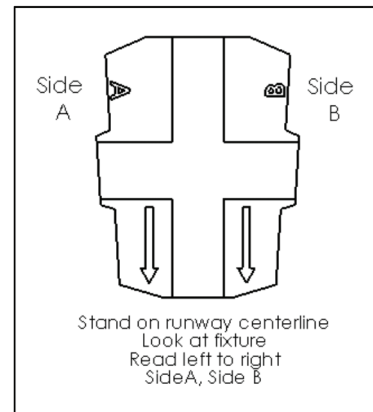

Figure 2: Side A, Side B

Example: EHL-RG-24 is 24" high with red on side A and green on side B.



Catalog Ordering Information Continued

ICAO / TP312 Fixtures

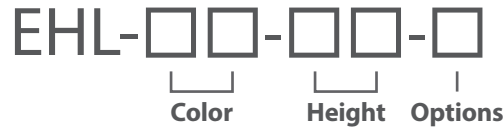

Color	Height	Options
WW = White / White	14 = 14" (36cm)	5 = Arctic Kit
WY = White / Yellow	20 = 20" (51cm)	
YW = Yellow / White	24 = 24" (61cm)	
WR = White / Red	30 = 30" (76cm)	
RW = Red / White	Other heights available	
RY = Red / Yellow		
YR = Yellow / Red		
RR = Red/Red		
RO = Red / Obscure		
OR = Obscure / Red		
IO = Green Threshold / Obscure*		
OI = Obscure / Green Threshold*		

***I = Green Threshold for ICAO and TP312**

Example: EHL-IO-24 is 24" high uni-directional fixture with green on side A.

White, Yellow and Red (W, Y, R) meet the runway light requirements for a runway 60m wide as stated in Annex 14, Appendix 2, A2-10 and TP312, Appendix B.1.11.

Red (R) meets the requirement for a runway end light as stated in Annex 14, Appendix 2, A2-8 and TP312, Appendix B.1.9.3

Green (I) meets the requirements for a threshold light as stated in Annex 14, Appendix 2, A2-3 and TP312, Appendix B.1.3.

Note: G represents a green light engine that does **NOT** meet ICAO or TP312 specifications. The green ICAO and TP312 threshold light must be designated as I when ordering a fixture.



DESCRIPTION



AirportLightingCompany

An ISO 9001:2015 Certified Company

Dimensions

Height, head assembly: 6.8 inches, (173mm)
Height, w/ slip fitter: 8.9 inches, (226mm)
Width: 5.5 inches, (140mm)
Length: 5.2 inches, (132mm)
Weight: 5 pounds, (2.3kg)

Single Box

(9 1/8 x 5 3/4 x 7 inches) or (232 x 178 x 1468mm)

9 Fixtures in a Box

(17 x 16 1/2 x 10 inches) or (432 x 420 x 254mm)

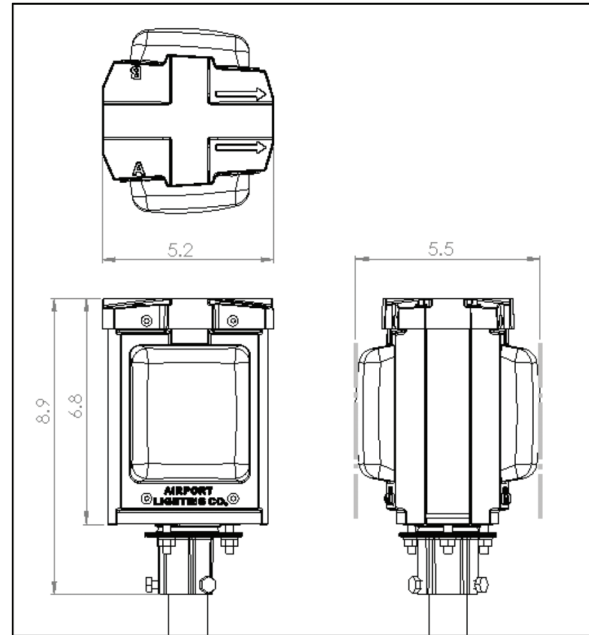

Figure 3: Fixture Dimensions

Storage

The Elevated High Intensity fixtures should be stored indoors and kept dry.

Storage Temperature: -55C (-67F) to +55C (131F).



FAA References and Siting Requirements

The requirements for siting of high intensity runway edge lights are explained in FAA advisory circular 150/5340-30J.

The L862E fixtures, bidirectional red/green and red/red, and unidirectional red or green will come with red and/or green lens retainers to provide daytime recognition.

Installation

Tools Required for Installation:

- 7/16 wrench
- 1 ½ inch wrench

Tools Required for Maintenance:

- 7/16 wrench
- 1 ½ inch wrench
- Torx T20 driver

Installation Precautions

It is not safe to work on a constant current power system when the power is on. Make sure the power is off before installing a light fixture. A Lock Out Tag Out procedure is strongly recommended. An additional safety measure is to test circuit by using a clamp on current meter. By clamping over the primary cable in the fixture can, the installer has performed an additional safety check by checking the circuit they are working on is off. At the vault make sure the Constant Current Regulator powering the circuit is off and has been tagged out. At the fixture, place a clamp-on ammeter over the primary cable and verify that the current measures zero amps.

Install Proper Transformer

It is recommended to use the specified transformer to power the High Intensity LED Runway Light. A smaller transformer will not allow the fixture to work properly. An oversized transformer can be used but will not work as efficiently. A 30/45-Watt isolation transformer is specified for all fixtures without an arctic kit. All fixtures that have an optional arctic kit require a 65W isolation transformer.

Install Fixture

Loosely install the column to the fixture and pass the secondary cable thru the column and frangible coupling. Connect the secondary to the transformer. Fasten the column to the frangible coupling with a torque of 64 inch-pounds (5.3 foot-pounds).

Install Frangible Coupling

Install frangible coupling into baseplate and torque to 50 ft-lbs. (68Nm). For a 62-1060 coupling into a 2in NPS baseplate, connect the 62-1060 to a 2in to 1 1/2in reducer, then install the reducer and coupling into the baseplate with a torque of 50 ft-lbs. (68Nm).

Aim Fixture

The arrows on the fixture cap should be pointed towards the runway centerline. The shorter cross on top of the cap is used to sight the fixture for alignment with the row of edge lights, the longer member of the cross can be used to align with the threshold lights.

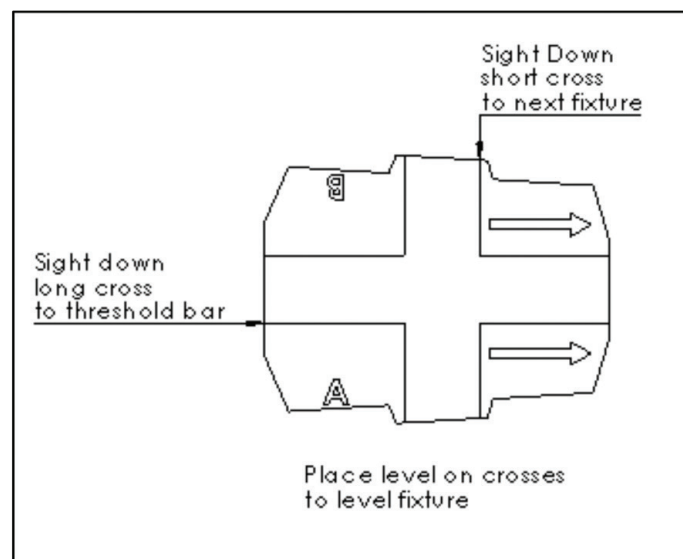

Figure 4: Fixture Aiming



Level Fixture

Place a level on top of the cap and level the fixture. If a torpedo level is used, level in both directions of the cross. A bull's eye level can be used at the cross intersection.

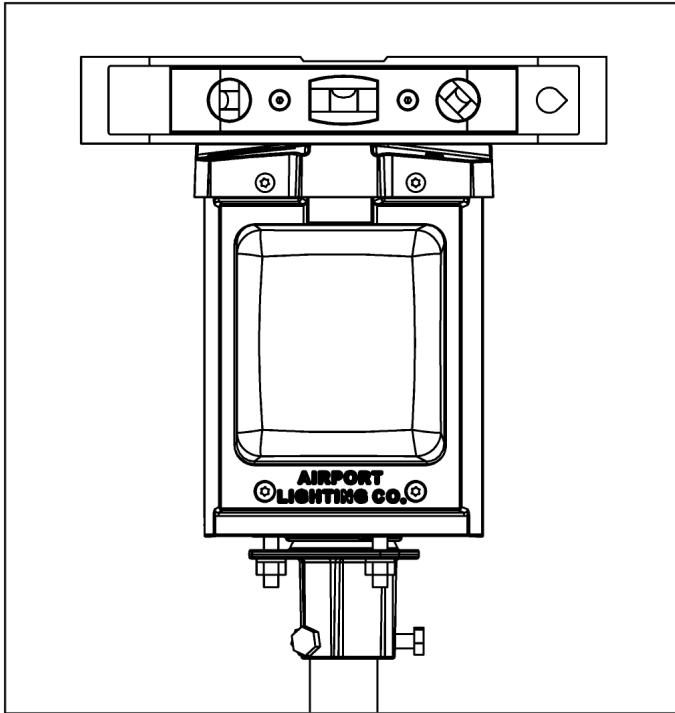

Figure 5: Leveling, Front View

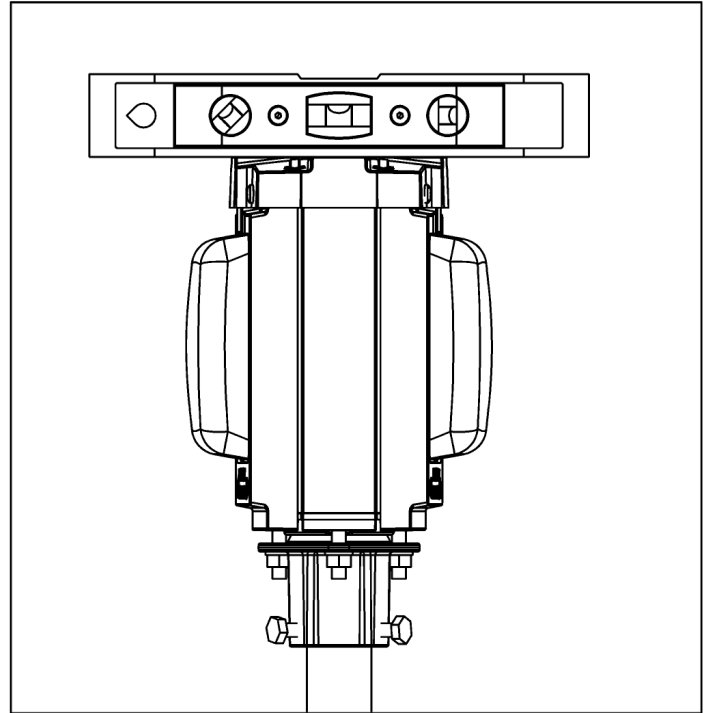

Figure 6: Leveling, Side View

Torque Bolts

Once the fixture has been aimed and leveled, torque the 1/4-20 fasteners to 64 inch-pounds (5.3 foot-pounds). Recheck the level of the fixture.

Table 1: Torque

	Inch-pounds	Foot-pounds	Newton-meters
#8	18.4	1.5	2.1
1/4-20	63.6	5.3	7.2
1 1/2 & 2	na	50	68

Operation

The L862 LED product line is designed to work on a constant current electrical supply that delivers current from 2.8 amps to 6.6 amps. The fixture measures the input current and automatically adjusts the light intensity. The fixture contains an input board, a controller, and light engine(s). The fixture senses which color will be emitted by the light engine and adjusts its power accordingly. Change of light engine to a different color requires no user adjustments.

Inspect that the fixture is properly installed and connected to the correct isolation transformer. Turn on the fixture and the LEDs come on. Step the current level and the light intensity will adjust to the correct intensity. When stepping current, allow a few seconds for the intensity to readjust.

Plug and Know LED Circuit

The ALC L-862 light engines use a 6-pin connector. 2 of the 6 pins provide power to the LEDs. The remaining 4 pins are used to identify the light engine. When a light engine is connected to the fixture, the fixture knows which light engine has been connected. This allows the circuit to properly drive each light engine to its correct intensity.

Multiple Light Devices

The light engines are made up of multiple LEDs. FAA requires the fixture to shut off if 25% of the LEDs fail. The circuit is constantly looking at the LEDs. When 25% or more fail, the circuit will power down within 2 minutes and a minute later it will shut the fixture off. If the fixture is off, do not touch the fixture. There is still power going to the fixture. If a fixture appears to be off, cycle the power off and on. Observe the light engines. Replace the light engine that does not have all the LEDs working.

Arctic Kit

The optional arctic kit operates in series with the L-862(L) fixture. A thermostat determines whether the arctic kit is needed. If the temperature is low, the thermostat sends power to the heater(s) and the glass lens is heated. If the temperature is high, the thermostat shorts and only the fixture sees power.



Daily Maintenance

- **Check that all lights are working.**
- **Check that all lights have similar light output.**
- **Check that the lenses are clean.**

Monthly Maintenance

- **Check that all fixtures are aimed properly.**
- **Check that all fixtures are level on 2 axes.**
- **Check that the fixture is secure, and all fasteners are tight.**
- **Check that all LEDs are illuminated.**
- **Clean the lenses.**

Tech Support

Outside of aiming, leveling, and cleaning, the L-862 LED should require very little maintenance. The end user has the option to use this manual to perform advanced maintenance, to call tech support at Airport Lighting Company at (866) 212-1060 or to contact us by email at support@airportlightingcompany.com.

Tech support can provide the end user with an RMA, Return Merchandise Authorization number. Once the fixture has been evaluated by ALC, you will be either granted a warranty replacement, the option to repair the fixture or the option to purchase a new fixture.

Table 2: Troubleshooting

Problem	Cause	Solution
Light output too low	Glass is dirty	Clean lens
	Wrong current level	Check current on CCR
	Isolation transformer too small	Install the proper sized transformer
	LED light engine is failing	Replace light engine
	Controller is failing	Replace controller
Only one side of fixture has light output	LED light engine is disconnected	Check light engine connection
	LED light engine has failed	Replace light engine
	Controller has failed	Replace controller
Both sides of fixture, no light output	Connection failed	Check all connections
	LED light engine(s) failed	Replace light engine(s)
	Controller failed	Replace controller
	Power input board failed	Replace power input board
	Arctic Kit has open circuit	Check arctic kit connections
Condensation inside lens	Excess humidity	It will clear itself

Replacing Electronic Parts

When the light is out the cause can be in a few areas. The way to isolate the problem is to start with a known good fixture. Test each part from the inoperable fixture in the known good fixture, one at a time, until the problem is isolated. Then replace the defective part.

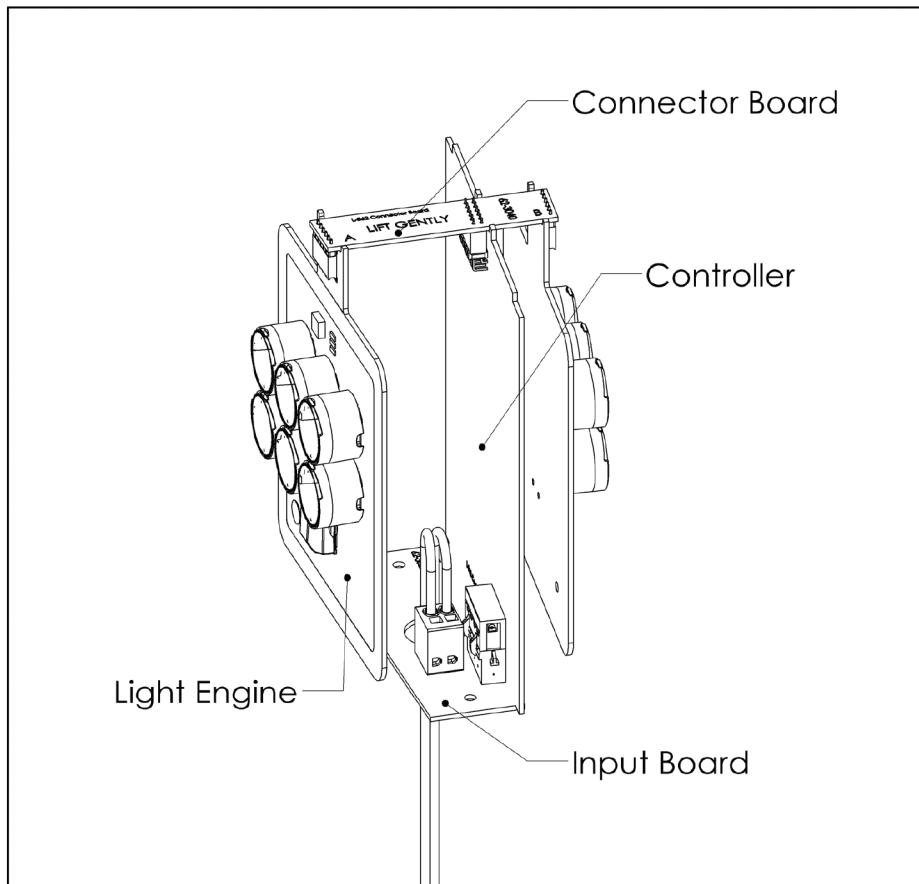

Figure 7: Electronic Component Assembly

- **Note which side is side A and which side is side B.**
- **Remove the 4 screws that hold the cap in place.**
- **Remove the cap.**
- **Carefully pull the connector board upward to disconnect.**
- **Remove the 2 screws that hold the side A lens retainer in place.**
- **Remove side A LED light engine.**
- **Remove the 2 screws that hold the Side B lens retainer in place.**
- **Remove side B LED light engine.**
- **Pull the connector board upward and out of the fixture.**
- **Remove the 4 screws holding the bottom to the body.**

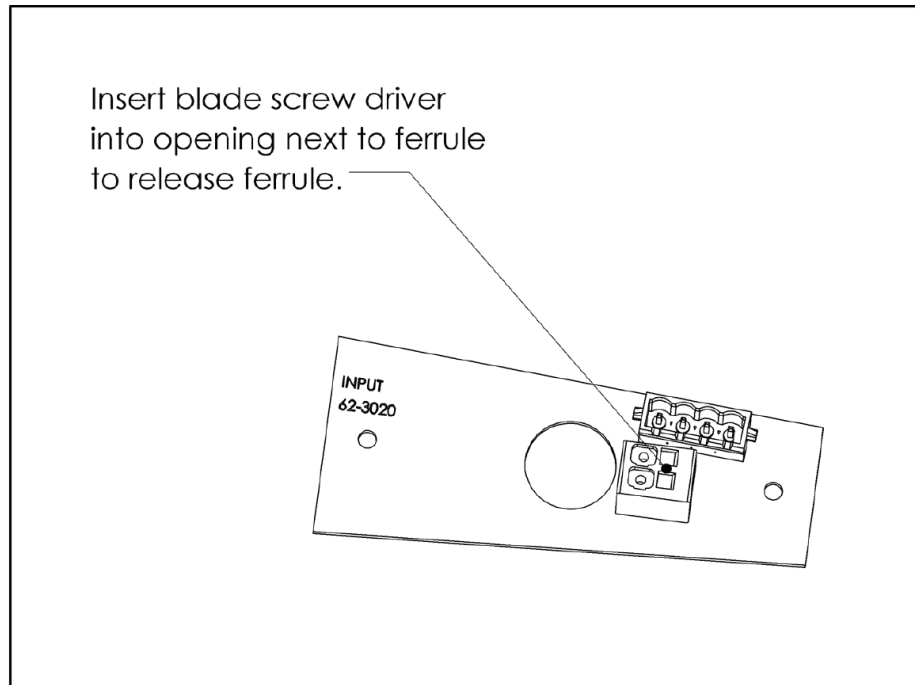

Figure 8: How to Remove Ferrule

- Insert a small blade screwdriver into the openings next to the ferrules to release the ferrules.
- Remove the 2 screws holding the input board to the bottom.

Replacing Electronic Parts

- Connect the input board to the bottom with 2 screws.
- Push the ferrules into the input board terminal block until the ferrules are flush with the top of the terminal block.
- Position the controller board into the input board.
- Slide the controller board into the body. Make sure the board is in the grooves correctly.
- Connect the bottom to the body with 4 screws.
- Install the connector board to the controller.
- Use the cap to determine Side A and Side B.
- Slide Side A light engine into the connector board.
- Place the lens retainer over the light engine.
- Make sure the top edges are flush.
- Install the 2 lower screws.
- Slide Side B light engine into the connector board.
- Place the retainer over the light engine.
- Make sure the top edges are flush.
- Install the 2 lower screws.
- Place the cap in position and apply a downward pressure while installing 4 screws.

High Intensity Runway Light LED Light Engines

There are 5 different light engines to choose from. There is 1 white, 1 yellow, 1 red and 2 green light engines. Each light engine meets a specification or multiple specifications. All specifications are met when the fixture is aimed properly. Table 4 shows the available light engines. All light engines work on either side of a fixture.

Table 3: Light Engines

Color	Order Code	Light Engine w/ Lens	Light Engine w/ Lens & AK	LEDs	FAA	ICAO
White	W	262-1200	262-1200-5	7	L862	A2-10 Runway Edge Light to 60m wide
Yellow	Y	262-1201	262-1201-5	7	L862	A2-10 Runway Edge Light to 60m wide
Red	R	262-1202	262-1202-5	7	L862 L862E	A2-10 A2-8 Runway Edge Light to 60m wide. Runway End Light
Green	G	262-1203	262-1203-5	4	L862 L862E	
Green	I	262-1204	262-1204-5	9		A2-3 Threshold Light

Column and Cords Part Numbers

Table 4: Columns and Cords

Fixture Height	Column Part Number	Cord PN
14 inches (36cm)	77	262-1100
20 inches (51cm)	78	262-1101
24 inches (61cm)	78-16	262-1102
30 inches (76cm)	79	262-1103

Parts Diagram

Item	Part Number	Qty.
1	262-2400 L862 Cap w/Gasket	1
2	62-1010, L862 Body	1
3	62-3040, L862 Connector Board	1
4	62-3010, L862 Controller	1
5	62-3020, L862 Input Board	1
6	62-1040, L862 Bottom	1
7	62-1050, L862 Slip Fitter	1
8	Column (see table)	1
9	62-1060, Hex Coupling	1
10	62-1030, L862 Retainer	1 or 2
11	62-1070, L862 LED Lens	1 or 2
12	62-2020, Lens Gasket	1 or 2
13	Light Engine (see table)	1 or 2
14	99-00109, Strain Relief	1
15	99-00244, #8 Torx T20	12

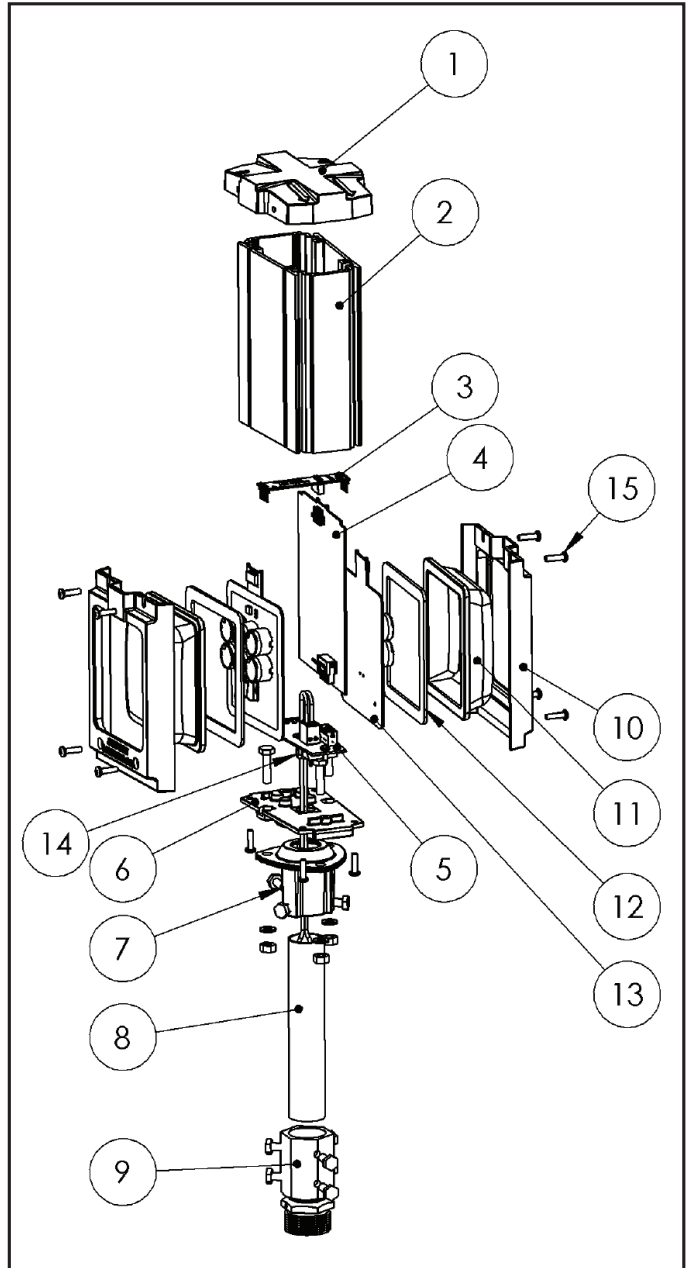

Figure 9: Parts Diagram

Arctic Kit Parts

Item	Part Number	Description
1	62-3025	PCB AK Input Board
2	62-3050	PCB Thermostat Board
3	62-3060	Heater

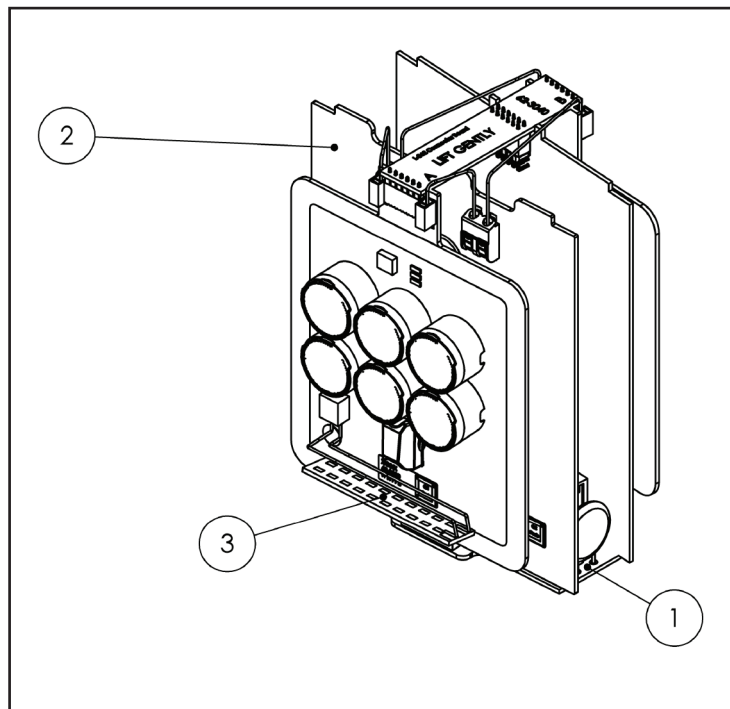

Figure 10: Arctic Kit Parts

Table 5: Bill of Materials

Part Number	Name	Description
62-1010	L862 Body	Extrusion body
262-2400	Cap w/ Gaskets	Die cast cap
62-1030	L862 Retainer Yellow	Die cast yellow lens retainer
62-1031	L862 Retainer Red	Die cast red lens retainer
62-1032	L862 Retainer Green	Die cast green lens retainer
62-1033	L862 Retainer Blank	Solid retainer, obscure side of unidirectional
62-1040	L862 Bottom	Die cast bottom
62-1050	L862 Slip Fitter	Die cast slip fitter
62-1060	Hex Coupling	Frangible coupling
62-3010	PCB Controller	PCB controls unit
62-3020	PCB Input Board	PCB input connection
62-3025	PCB AK Input Board	PCB input connection (arctic kit option)
62-3040	PCB Connector Board	PCB connects light engines to controller
62-3050	PCB Thermostat Board	Thermostat board (arctic kit option)
62-3060	PCB Heater Board	Heater (arctic kit option)
262-1200	Light Engine Ass'y, White	White 7 LED light engine with lens and gasket
262-1201	Light Engine Ass'y, Yellow	Yellow 7 LED light engine with lens and gasket
262-1202	Light Engine Ass'y, Red L862	Red 7 LED light engine with lens and gasket
262-1203	Light Engine Ass'y, Green L862	Green 4 LED light engine with lens and gasket
262-1204	Light Engine Ass'y, ICAO Threshold	Green 9 LED light engine with lens and gasket
262-1100	L862(L) Cord Set, 14" OAH	L-823, Style 6 for 14" (36cm) EHL Fixture
262-1101	L862(L) Cord Set, 20" OAH	L-823, Style 6 for 20" (51cm) EHL Fixture
262-1102	L862(L) Cord Set, 24" OAH	L-823, Style 6 for 24" (61cm) EHL Fixture
262-1103	L862(L) Cord Set, 30" OAH	L-823, Style 6 for 30" (76cm) EHL Fixture
77	Column for 14	Column for 14 (36cm)
78	Column for 20	Column for 20 (51cm)
78-16	Column for 24	Column for 24 (61cm)
79	Column for 30	Column for 30 (76cm)
99-00244	8-32 x 5/8 Torx Pan Taplite SS	Hardware, T20
903	Thread Reducer	2" NPT to 1 1/2-12 NF thread reducer

Table 6: Arctic Kit Bill of Materials

Part Number	Name	Description
62-3025	PCB AK Input Board	Input Board
62-1033	L862 Retainer Blank	Solid retainer, obscure side of unidirectional
62-3050	PCB Thermostat Board	Thermostat board
62-3060	PCB Heater Board	Heater
62-3065	Heater Tape	Heater tape
262-1200-5	Light Engine Ass'y, White	White lens and light engine
262-1201-5	Light Engine Ass'y, Yellow	Yellow lens and light engine
262-1202-5	Light Engine Ass'y, Red	Red lens and light engine
262-1203-5	Light Engine Ass'y, Green	Green lens and light engine
262-1204-5	Light Engine Ass'y, ICAO Threshold	ICAO green lens and light engine



WIRING DIAGRAM

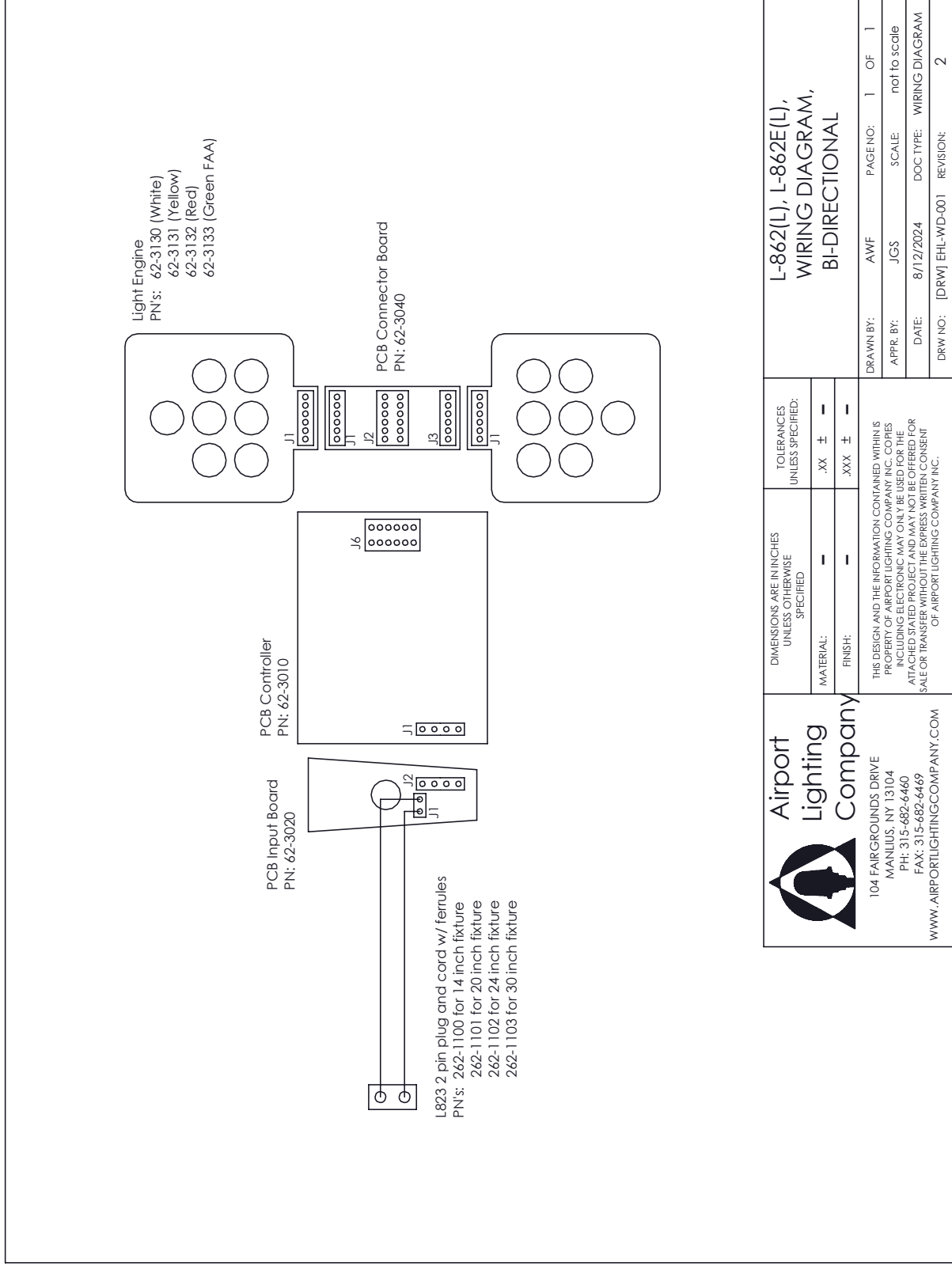

Figure 11: Schematic, Bi-directional Fixture



WIRING DIAGRAM



Airport Lighting Company
An ISO 9001:2015 Certified Company

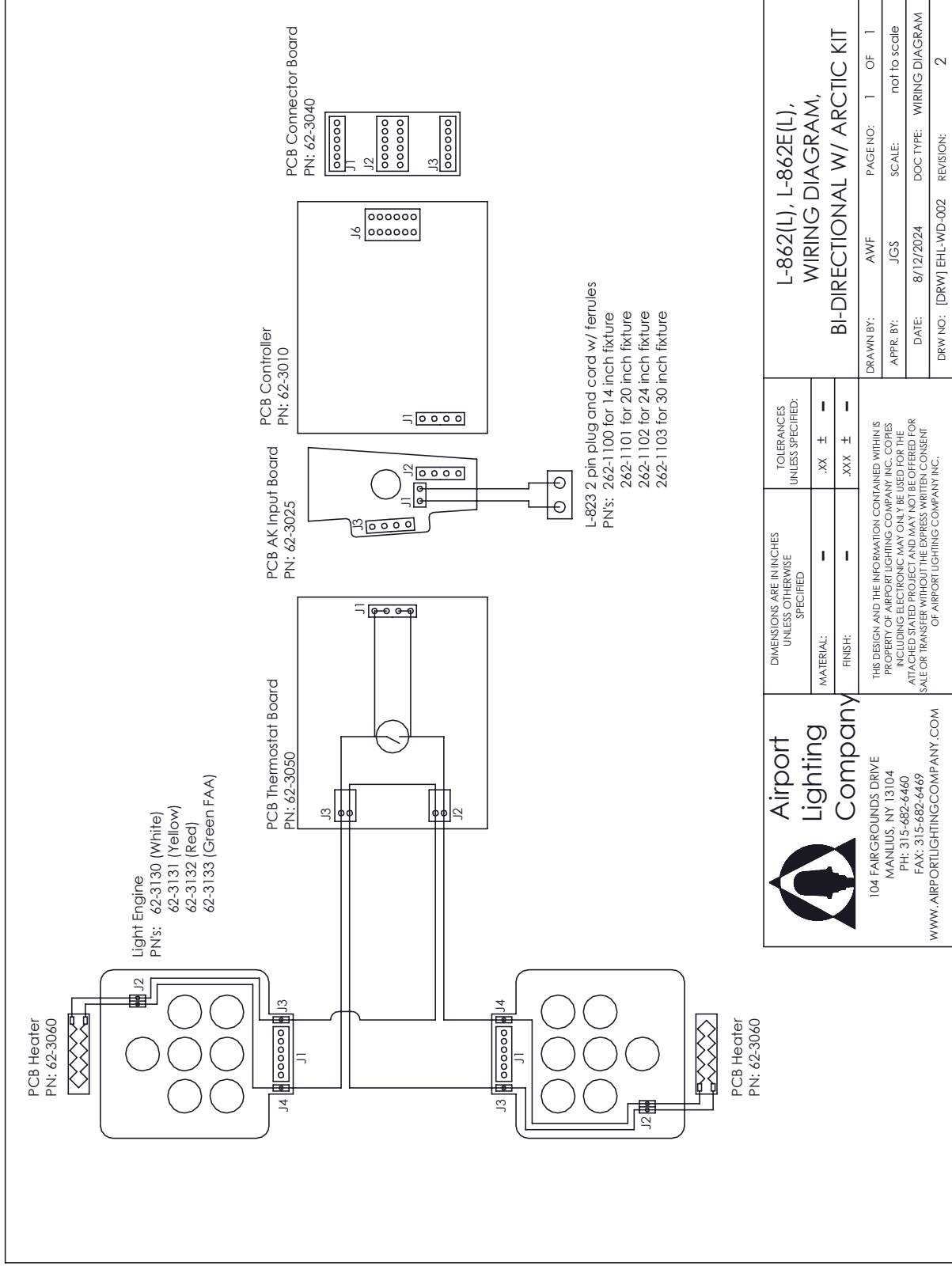

Airport Lighting Company
104 FAIRGROUNDS DRIVE
MANLIUS, NY 13104
PH: 315-682-6460
FAX: 315-682-6469
WWW.AIRPORTLIGHTINGCOMPANY.COM

DIMENSIONS ARE IN INCHES UNLESS OTHERWISE SPECIFIED	TOLERANCES UNLESS SPECIFIED:
MATERIAL: -	.XX ± -
FINISH: -	.XXX ± -
THIS DESIGN AND THE INFORMATION CONTAINED WITHIN IS PROPERTY OF AIRPORT LIGHTING COMPANY INC. COPIES INCLUDING ELECTRONIC MAY ONLY BE USED FOR THE ATTACHED STATED PROJECT AND MAY NOT BE OFFERED FOR SALE OR TRANSFER WITHOUT THE EXPRESS WRITTEN CONSENT OF AIRPORT LIGHTING COMPANY INC.	

L-862(L), L-862E(L), WIRING DIAGRAM, BI-DIRECTIONAL W/ ARCTIC KIT	
DRAWN BY: AWF	PAGE NO: 1 OF 1
APPR. BY: JGS	SCALE: not to scale
DATE: 8/12/2024	DOC TYPE: WIRING DIAGRAM
DRW NO: [DRW] EHL-WD-002	REVISION: 2

Figure 12: Schematic, Bi-directional Arctic Kit



WIRING DIAGRAM

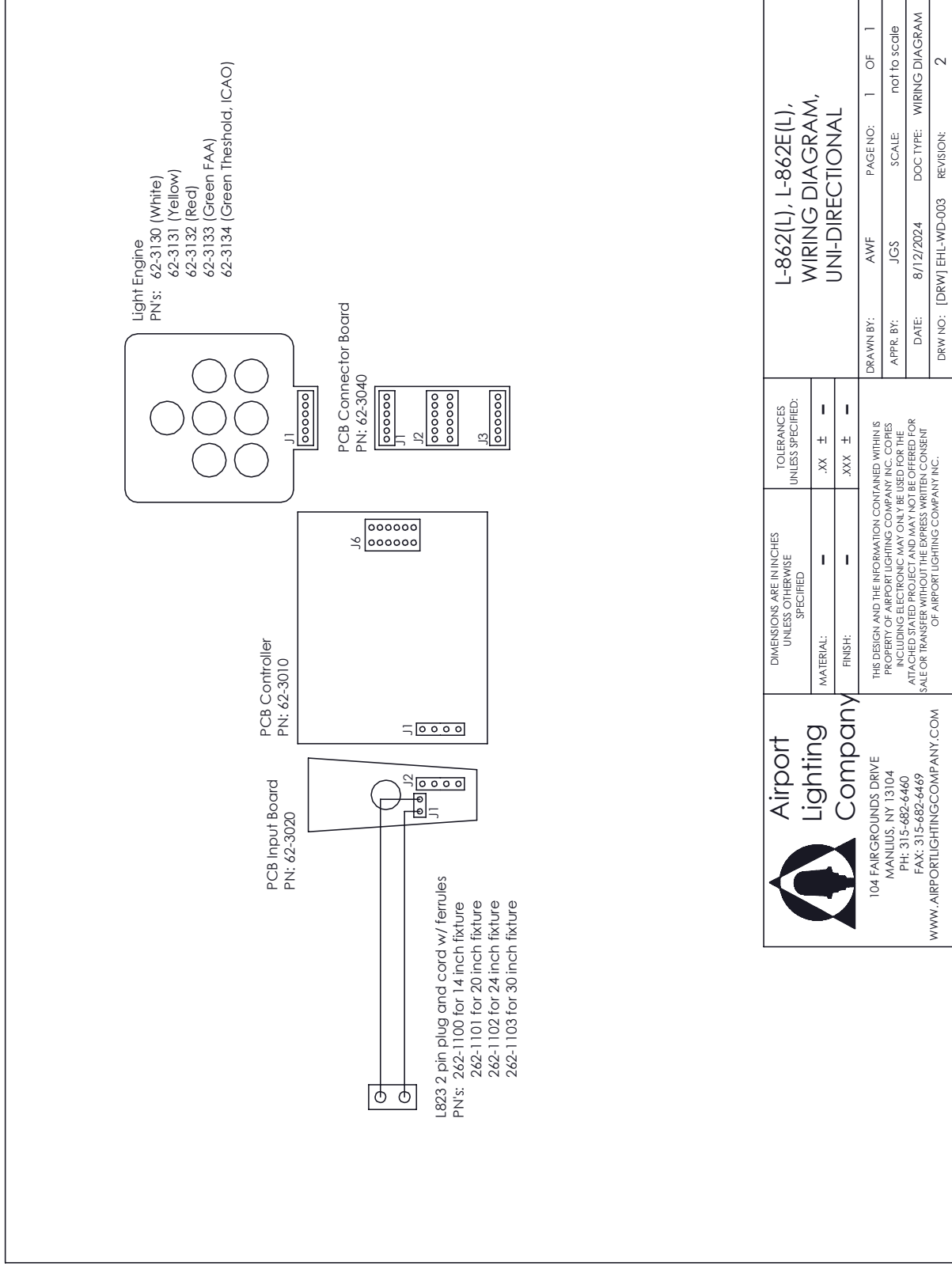

Airport Lighting Company
104 FAIRGROUNDS DRIVE
MANLIUS, NY 13104
PH: 315-682-6460
FAX: 315-682-6469
WWW.AIRPORTLIGHTINGCOMPANY.COM

DIMENSIONS ARE IN INCHES UNLESS OTHERWISE SPECIFIED	TOLERANCES UNLESS SPECIFIED:	L-862(L), L-862E(L), WIRING DIAGRAM, UNI-DIRECTIONAL	
	MATERIAL:	.XX ±	
FINISH:	.XXX ±		
THIS DESIGN AND THE INFORMATION CONTAINED WITHIN IS PROPERTY OF AIRPORT LIGHTING COMPANY INC. COPIES INCLUDING ELECTRONIC MAY ONLY BE USED FOR THE ATTACHED STATED PROJECT AND MAY NOT BE OFFERED FOR SALE OR TRANSFER WITHOUT THE EXPRESS WRITTEN CONSENT OF AIRPORT LIGHTING COMPANY INC.			
DRAWN BY:	AWF	PAGE NO:	1 OF 1
APPR. BY:	JGS	SCALE:	not to scale
DATE:	8/12/2024	DOC TYPE:	WIRING DIAGRAM
DRW NO:	[DRW] EHL-WD-003	REVISION:	2

Figure 13: Schematic, Uni-directional Fixture



WIRING DIAGRAM



Airport Lighting Company
An ISO 9001:2015 Certified Company

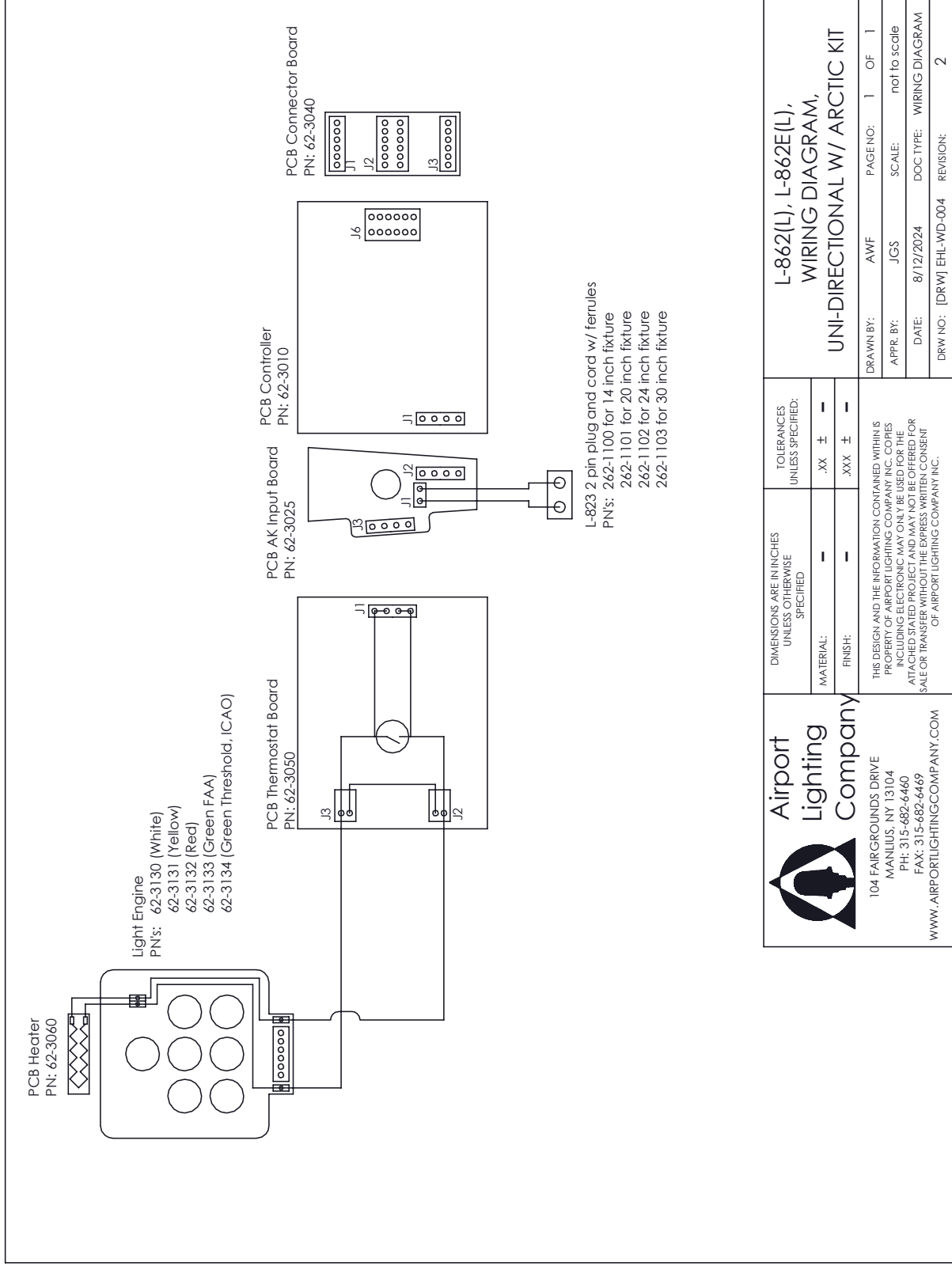

Airport Lighting Company
104 FAIRGROUNDS DRIVE
MANLIUS, NY 13104
PH: 315-682-6460
FAX: 315-682-6469
WWW.AIRPORTLIGHTINGCOMPANY.COM

DIMENSIONS ARE IN INCHES UNLESS OTHERWISE SPECIFIED	TOLERANCES UNLESS OTHERWISE SPECIFIED:
MATERIAL: -	.XX ± -
FINISH: -	.XXX ± -
THIS DESIGN AND THE INFORMATION CONTAINED WITHIN IS PROPERTY OF AIRPORT LIGHTING COMPANY INC. COPIES INCLUDING ELECTRONIC MAY ONLY BE USED FOR THE ATTACHED STATED PROJECT AND MAY NOT BE OFFERED FOR SALE OR TRANSFER WITHOUT THE EXPRESS WRITTEN CONSENT OF AIRPORT LIGHTING COMPANY INC.	

L-862(L), L-862E(L), WIRING DIAGRAM, UNI-DIRECTIONAL W/ ARCTIC KIT	
DRAWN BY: AWF	PAGE NO: 1 OF 1
APPR. BY: JGS	SCALE: not to scale
DATE: 8/12/2024	DOC TYPE: WIRING DIAGRAM
DRW NO: [DRW] EHL-WD-004	REVISION: 2

Figure 14: Schematic, Uni-directional with Arctic Kit

